

Outdoor Collection

Woodbridge Gas Fireplaces



Outdoor See-Thru Gas Fireplaces

See-thru fireplaces are the perfect design feature to include in any outdoor entertaining space.

They create a flow between two areas and provide the warm ambience of flames with a contemporary edge.

SS-36-ST, SS-48-ST, SS-60-ST, SS-72-ST

Innovative Design
Quality
Durability
Reliability



Model SS-36-ST shown

Outdoor Collection

Woodbridge Gas Fireplaces

SS-36-ST, SS-48-ST, SS-60-ST, SS-72-ST

Standard Features

- * Can be framed in wooden structure and finished with non-combustible facing materials.
- * Ceramic glass wind baffles.
- * High grade 304 stainless steel construction.
- * Dynamic flame reflection from ember bed and brushed stainless steel chamber.
- * Stainless steel flex connector and gas shut-off valve.
- * Electronic ignition system.
- * Remote control or On/Off wall switch.
- * Limited Lifetime Warranty on burner and firebox.

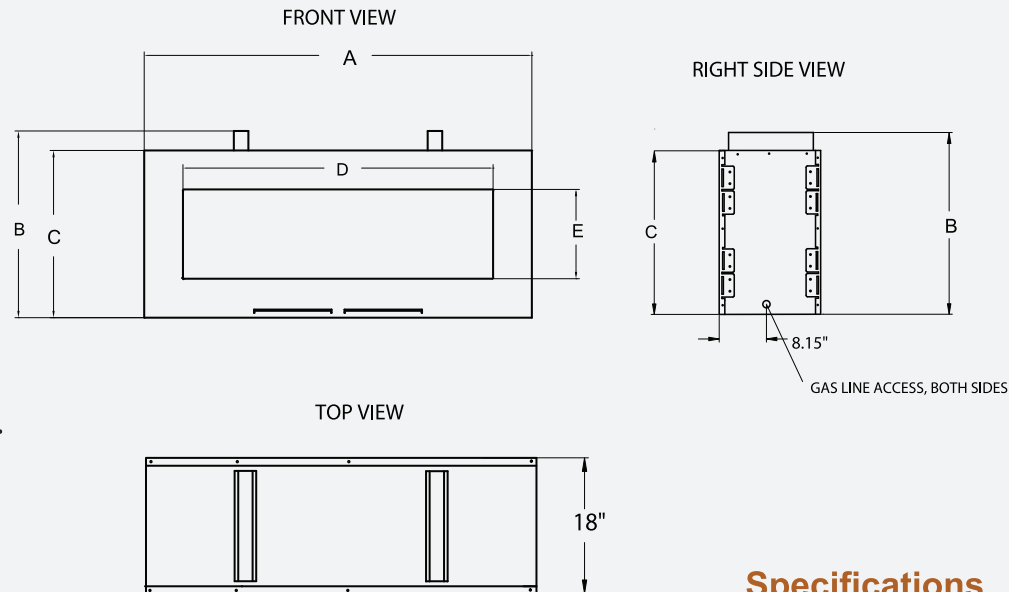

Media options:

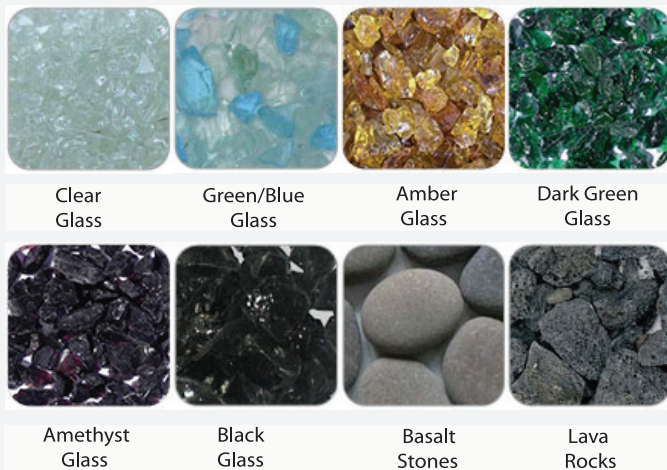

	SS-36-ST	SS-48-ST	SS-60-ST	SS-72-ST
A	48"	60"	72"	84"
B	33.75"	29.75"	31.75"	31.75"
C	29.75"	25.75"	25.75"	25.75"
D	36"	48"	60"	72"
E	17.31"	13.75"	13.75"	13.75"

Specifications

Model:	SS-36-ST	SS-48-ST
Gas Input Rate NG, Btu/h	40,000	60,000
LP, Btu/h	38,000	56,000

	SS-60-ST	SS-72-ST
Gas Input Rate NG, Btu/h	75,000	90,000
LP, Btu/h	75,000	90,000

**Please refer to Owners Manual
for installation instructions**



Report # 0401GF006S